

# WZ-H5-N Long Life Anti-Interference Formaldehyde Detection Module



**ProSense Technologies Co., Ltd.**



## Copyright Notice

The copyright of this manual belongs to ProSense Technologies Co., Ltd. No part of this manual may be excerpted, copied, translated, annotated, or edited in any form without the written permission of ProSense Technologies Co., Ltd. Infringement will be pursued.

To ensure proper use of our product, please read this manual carefully and follow the recommended usage instructions. The company shall not be liable for any damage caused by improper use, or by unauthorized removal, disassembly, or replacement of internal components of the sensor.

We are committed to customer-oriented solutions, pursuing high-quality user experience and technological innovation. Both new and old customers are welcome to discuss product applications with us.

**Manual Version: WZ-H5-N-V 1.0**

**ProSense Technologies Co., Ltd.  
March 19, 2026**





### Brief Introduction

The WZ-H5-N long-life anti-interference formaldehyde detection module is a newly launched fifth-generation anti-interference formaldehyde detection module. Based on the excellent anti-interference performance and stability of the WZ-H3-N module, it significantly improves adaptability to environmental changes. The product still adopts automotive-grade fuel cell solid electrolyte and ProSense’s targeted noble metal catalyst, featuring zero leakage, no drying out, no liquid leakage, wide temperature tolerance, and long service life. It is an ideal choice for high-precision formaldehyde detection.

### Typical Applications

- HCHO detection in vehicle
- Air conditioners
- Smart home
- Portable devices
- Wearable devices
- Air purifier
- ... ..

### Key Features

- Selective formaldehyde detection
- Wide temperature range stability(-40°C to 70°C)
- High stability
- More than six years of service life
- Low power consumption
- Fast response
- Over 4 million units of field operation experience

### Diagram

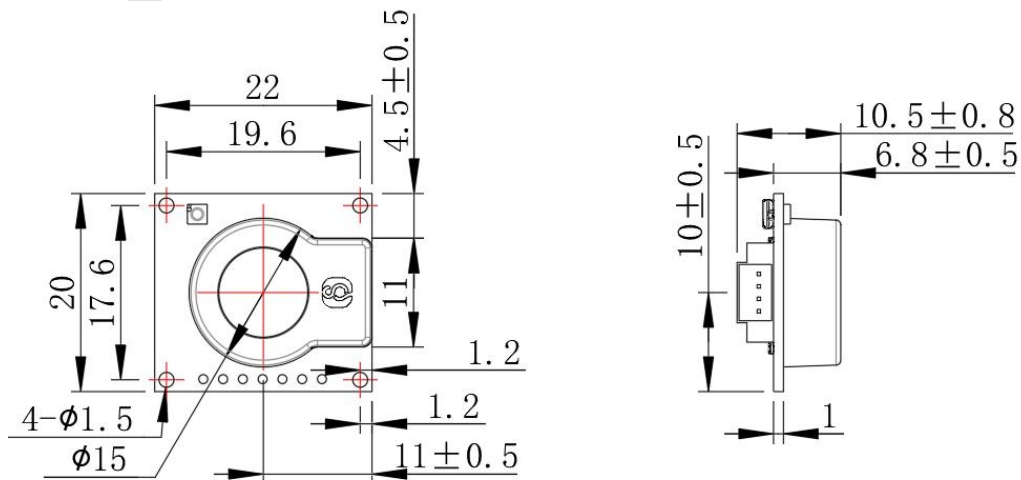



## Definition of Pins

PIN	DEFINITION
Pin1	Vin(5V)
Pin2	GND
Pin3	RXD (0~3.3V data input)
Pin4	TXD( 0~3.3V data output)

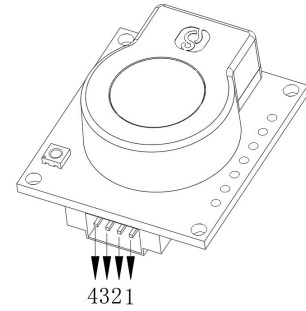

## Technical Specification

MODEL	WZ-H5-N
Detection Principle	Fuel cell
Detectable Gas	HCHO
Detection Range	0-1ppm
Overload	5ppm
Input Voltage	4.5-7V
Response Time (T90)	<90S
Resolution	0.001ppm
Accuracy	±25ppb or ±10%, whichever is greater (25±3℃) (50±5%RH)
Operating temperature range	-40℃~70℃
Operating Humidity Range	10%—90%RH (non-condense)
Lifetime	6 years in air
Warranty Period	12 months
Weight	2.6g

## Cross Sensitivity

Interference Gas	Concentration of Interference Gas(ppm)	Concentration of HCHO(ppm)
C <sub>2</sub> H <sub>5</sub> OH	2	<0.02
C <sub>6</sub> H <sub>6</sub>	10	0
CH <sub>3</sub> COOH	10	0



NH <sub>3</sub>	10	0
CO	1000	6
H <sub>2</sub>	1000	6

## Communication Protocol

### ➤ General Settings

Module makes use of serial communication.

Communication configuration parameters are:

Baud rate	9600
Data bits	8 bits
Stop bit	1 bit
Parity bit	None

Note: 1 data bit  $\approx$  104  $\mu$ s. Delay >100 ms after each command.

### ➤ 3.3V TTL Level Limits

Table 31-1. D.C. Electrical Characteristics

( $V_{DD} - V_{SS} = 2.4 \sim 5.5$  V,  $T_A = 25$  °C)

Symbol	Parameter	Condition	Min.	Typ.	Max.	Unit
<b>Supply voltage</b>						
$V_{DD}$	Operating voltage	F = 0 to 16 MHz	2.4	-	5.5	V
<b>I/O</b>						
$V_{IL}$	Input low voltage (I/O with TTL input)		$V_{SS}-0.3$	-	$0.2V_{DD}-0.1$	V
$V_{IL1}$	Input low voltage (I/O with Schmitt trigger input, $\overline{RST}$ , and XIN)		$V_{SS}-0.3$	-	$0.3V_{DD}$	V
$V_{IH}$	Input high voltage (I/O with TTL input)		$0.2V_{DD}+0.9$	-	$V_{DD}+0.3$	V
$V_{IH1}$	Input high voltage (I/O with Schmitt trigger input and XIN)		$0.7V_{DD}$	-	$V_{DD}+0.3$	V
$V_{IH2}$	Input high voltage ( $\overline{RST}$ )		$0.8V_{DD}$	-	$V_{DD}+0.3$	V

Symbol	Parameter	Condition	Min.	Typ.	Max.	Unit
$V_{OH}$	Output high voltage (quasi-bidirectional mode)	$V_{DD} = 5.5$ V, $I_{OH} = - 590$ $\mu$ A	2.4	-	-	V
		$V_{DD} = 4.5$ V, $I_{OH} = - 380$ $\mu$ A	2.4	-	-	
		$V_{DD} = 3.0$ V, $I_{OH} = - 100$ $\mu$ A	2.4	-	-	
		$V_{DD} = 2.4$ V, $I_{OH} = - 40$ $\mu$ A	2.0	-	-	
$V_{OH1}$	Output high voltage (push-pull mode)	$V_{DD} = 5.5$ V, $I_{OH} = - 20$ mA	2.4	-	-	V
		$V_{DD} = 4.5$ V, $I_{OH} = - 13$ mA	2.4	-	-	
		$V_{DD} = 3.0$ V, $I_{OH} = - 3.5$ mA	2.4	-	-	
		$V_{DD} = 2.4$ V, $I_{OH} = - 2$ mA	2.0	-	-	



### ➤ Communication Command

There are two communication types: active upload type and Q&A type. The default type is active upload and it sends gas concentration once every second. Commands are as follow:

0	1	2	3	4	5	6	7	8
Start	Gas	Unit ppb	No decimal byte	Concentration (High byte)	Concentration (low byte)	Full range (high byte)	Full range (low byte)	Check sum
0xFF	CH2O=0x17	Ppb=0x04	0x00	0x00	0x25	0xXX	0xXX	0x25

Gas concentration = concentration (high byte)\*256 + concentration (low byte)

(The high byte and low byte of the concentration must be converted from hexadecimal to decimal before being substituted into this formula for calculation.)

#### Switch to Q&A mode:

0	1	2	3	4	5	6	7	8
Start	Reserved	Switch command	Q&A	Reserved	Reserved	Reserved	Reserved	Checksum
0xFF	0x01	0x78	0x41	0x00	0x00	0x00	0x00	0x46

#### Switch to active upload mode:

0	1	2	3	4	5	6	7	8
Start	Reserved	Switch command	Active upload	Reserved	Reserved	Reserved	Reserved	Checksum
0xFF	0x01	0x78	0x40	0x00	0x00	0x00	0x00	0x47

#### To read gas concentration:

0	1	2	3	4	5	6	7	8
Start	Reserved	Command	Reserved	Reserved	Reserved	Reserved	Reserved	Checksum
0xFF	0x01	0x86	0x00	0x00	0x00	0x00	0x00	0x79

#### To return:

0	1	2	3	4	5	6	7	8
Start	Command	Concentration (High byte) (ug/m3)	Concentration (low byte) (ug/m3)	Reserved	Reserved	Concentration (High byte) (ppb)	Concentration (low byte) (ppb)	Checksum
0xFF	0x86	0x00	0x2A	0x00	0x00	0x00	0x20	0x30

Gas concentration = concentration (high byte)\*256 + concentration (low byte)



## Checksum calibration

```
/**
```

```
*Function name: unsigned char FucCheckSum(uchar *i,ucharIn)
```

```
*Function description: checksum calibration[Take Not(Byte1+Byte2+...Byte7) +1]
```

```
*Note: Take Not(Byte1+Byte2+...ByteX (X>2)
```

```
*/
```

```
unsigned char FucCheckSum(unsigned char *i, unsigned char In)
```

```
{  
    unsigned char j, tempq=0;  
    i+=1;  
    for(j=0; j<(In-2); j++)  
    {  
        tempq+=*i;  
        i++;  
    }  
    tempq=(~tempq)+1;  
    return(tempq);  
}
```

### Notes

- Avoid changing or moving sensor on the module.
- Avoid moving or changing electronic elements on PCB.
- Avoid exposure to organic vapour, organic solvent, high gas concentration.
- Protect from excessive vibration and shock.



PROSENSE

**ShenZhen ProSense Technologies Co., Ltd.**

**Visit us at:** [www.szprosense.com](http://www.szprosense.com)

**Phone:** 0755-36690079

**Email:** [sales@szprosense.com](mailto:sales@szprosense.com)

**Wechat:** 13510916915

**Add:** Building 4, Lianjian Industrial Park, Shanghenglang Community, Dalang Street, Longhua District, Shenzhen 518108, China