

WZ-H3-N Selective & High Temperature Resistant Formaldehyde Module

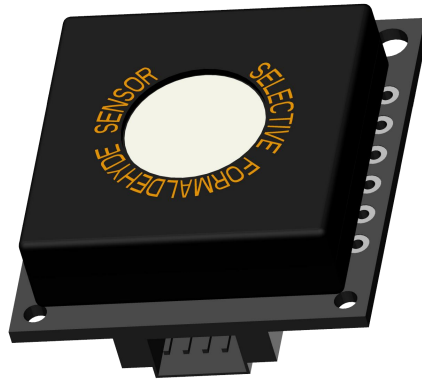

ProSense Technologies Co., Ltd.

Brief Introduction

WZ-H3-N selective & high temperature resistant formaldehyde module is the one launched specially for application in cases where temperature is higher than 60 °C . WZ-H3-N HCHO module is the first application of solid electrolyte integrated in fuel cell vehicles to HCHO detection ----real solid electrolyte, free from electrolyte leakage or dry out; WZ-H3-N selective HCHO module is free from the influence of the interference gases at low concentration, such as C₂H₅OH and can generate accurate detection result. WZ-H3-N selective HCHO module is pre-calibrated in the factory and can be integrated into your system directly.

Typical Applications

HCHO detection in vehicle
 Air conditioners
 Smart home
 Portable devices
 Wearable devices
 Air purifier

Key Features

Selective detection
 High temperature resistance
 High precision
 Fast response
 Long service life
 Low power consumption
 High stability

Diagram

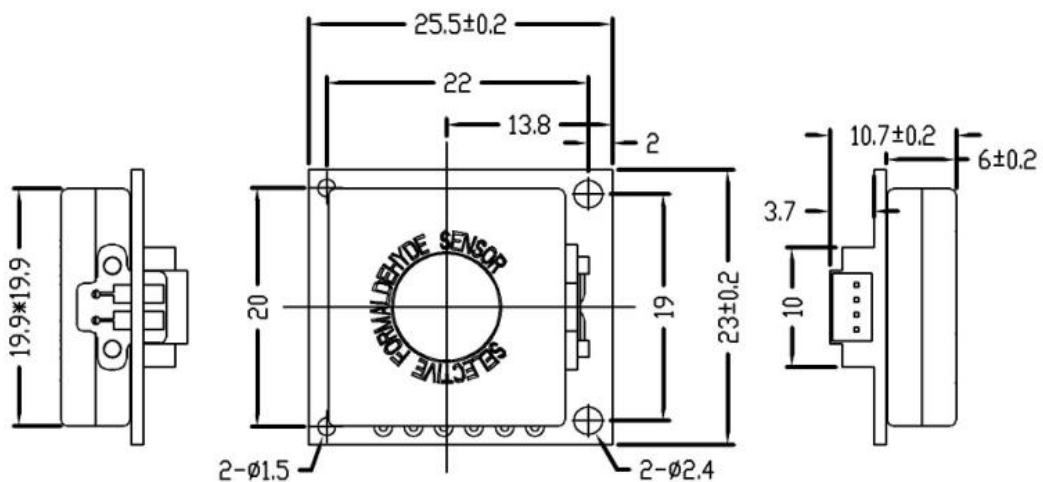

Definition of Pins

PIN	DEFINITION
Pin1	Vin(5V)
Pin2	GND
Pin3	RXD (0~3.3V data input)
Pin4	TXD(0~3.3V data output)

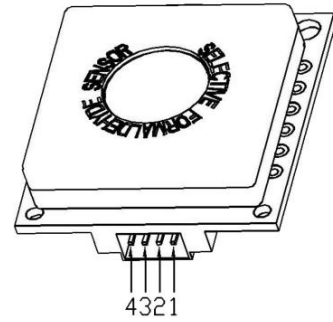

Technical Specification

MODEL	WZ-H3-N
Detection Principle	Micro fuel cell
Detectable Gas	HCHO
Detection Range	0-1ppm
Overload	5ppm
Input Voltage	4.5-7V
Response Time (T90)	<90S
Resolution	0.01ppm
Accuracy	±30ppb or ±10%, whichever is greater (25±3℃)(50±5%RH)
Operating temperature range	-40℃~70℃
Operating Humidity Range	10%—90%RH (non-condense)
Lifetime	6years in air
Warranty Period	12 months
Weight	4g

Cross Sensitivity

Interference Gas	Concentration of Interference Gas(ppm)	Concentration of HCHO(ppm)
C2H5OH	2	<0.04
C6H6	10	0

CH3COOH	10	0
NH3	10	0
CO	1000	6
H2	1000	6

Communication Protocol

➤ General Settings

Module makes use of serial communication.

Communication configuration parameters are:

Baud rate	9600
Data bits	8 bits
Stop bit	1 bit
Parity bit	None

➤ Communication Command

There are two communication types: active upload type and Q&A type. The default type is active upload and it sends gas concentration once every second. Commands are as follow:

0	1	2	3	4	5	6	7	8
Start	Gas	Unit ppb	No decimal byte	Concentration (High byte)	Concentration (low byte)	Full range (high byte)	Full range (low byte)	Check sum
0xFF	CH2O=0x17	Ppb=0x04	0x00	0x00	0x25	0xXX	0xXX	0x25

Gas concentration = concentration (high byte)*256 + concentration (low byte)

Switch to Q&A mode:

0	1	2	3	4	5	6	7	8
Start	Reserved	Switch command	Q&A	Reserved	Reserved	Reserved	Reserved	Checksum
0xFF	0x01	0x78	0x41	0x00	0x00	0x00	0x00	0x46

Switch to active upload mode:

0	1	2	3	4	5	6	7	8
Start	Reserved	Switch command	Active upload	Reserved	Reserved	Reserved	Reserved	Checksum
0xFF	0x01	0x78	0x40	0x00	0x00	0x00	0x00	0x47

To read gas concentration:

0	1	2	3	4	5	6	7	8
Start	Reserved	Command	Reserved	Reserved	Reserved	Reserved	Reserved	Checksum
0xFF	0x01	0x86	0x00	0x00	0x00	0x00	0x00	0x79

To return:

0	1	2	3	4	5	6	7	8
Start	Command	Concentration (High byte) (ug/m3)	Concentration (low byte) (ug/m3)	Reserved	Reserved	Concentration (High byte) (ppb)	Concentration (low byte) (ppb)	Checksum
0xFF	0x86	0x00	0x2A	0x00	0x00	0x00	0x20	0x30

Gas concentration = concentration (high byte)*256 + concentration (low byte)

Checksum calibration

/******

*Function name: unsigned char FucCheckSum(uchar *i,uchar ln)

*Function description: checksum calibration[Take Not(Byte1+Byte2+...Byte7) +1]

*Note: Take Not(Byte1+Byte2+...ByteX (X>2)

*****/

unsigned char FucCheckSum(unsigned char *i, unsigned char ln)

```
{
    unsigned char j, tempq=0;
    i+=1;
    for(j=0; j<(ln-2); j++)
    {
        tempq+=*i;
        i++;
    }
    tempq=(~tempq)+1;
    return(tempq);
}
```

Notes

- Avoid changing or moving sensor on the module.
- Avoid moving or changing electronic elements on PCB.
- Avoid exposure to organic vapour, organic solvent、 high gas concentration.
- Protect from excessive vibration and shock.

PROSENSE

 | 普 | 晟 | **ProSense Technologies Co., Ltd.**
PRO SENSE

Add: Building4, Lianjian S&T Park, LonghuaDistrict,Shenzhen,China;

Tel: +86 755 3669 0079

Website:<http://www.szprosense.com>

Email: sales@szprosense.com