PS-NH3-100 Ammonia Module

Operation Manual

PROSENSE

ProSense Technologies Co., Ltd.

Brief Introduction

PS-NH3-100 Ammonia Module, works on the proven fuel cell technology, is specified developed for the accuracy monitoring of NH3. The module combines novel NH3 sensor with advanced electronic control technology, converting NH3 concentration into PPM directly. Once NH3 arrives at working electrode (anode) it is oxidized instantaneously to generate an electrical signal. The electrical signal is then acquired and processed by microprocessor into a PPM value and is output by standard digital signal. PS-NH3-100 is pre-calibrated in the factory and can be integrated into your system directly. There's no consuming parts in the sensor which ensures the long service life.

Key Features

- Selective detection of NH3
- High precision
- Fast response
- Long service life
- High stability
- Low power

Typical Applications

- Smart toilet
- Pig farm
- Green building
- Detector / Monitor
- Intelligent home
-

Definition of Pins

PIN	DEFINITION
1	Vin(5V)
2	GND
3	RXD (0~3.3V data input)
4	TXD(0~3.3V data output)

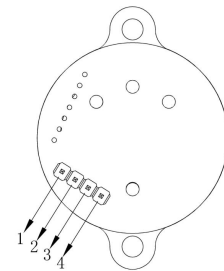

Diagram

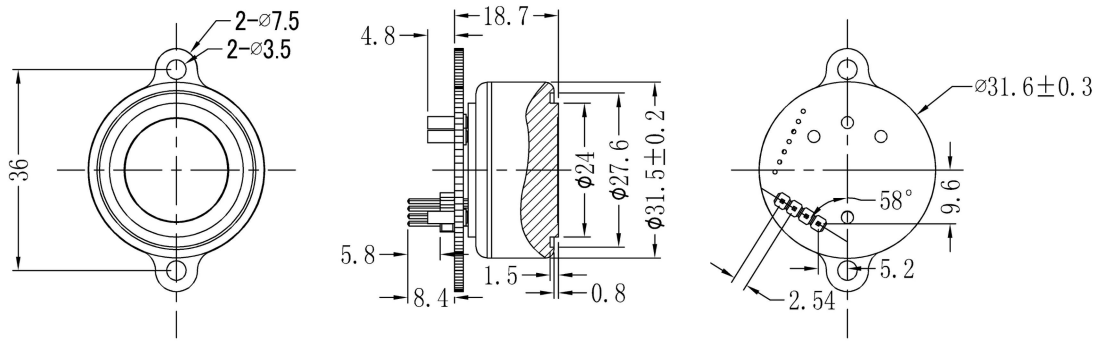

Technical Specification

MODEL	PS-NH3-100
Detection Principle	Micro fuel cell
Detectable Gas	NH3
Detection Range	0-100ppm
Overload	500ppm
Input Voltage	4.5-7V
Warm up time	<3min
Response Time (t90)	<120S
Recovery Time (t10)	<180S
Resolution	0.01ppm
Operating temperature range	-40℃~70℃
Operating Humidity Range	10%—90%RH (non-condense)
Storage Condition	3 years
Lifetime	12 months
Warranty Period	10g

Communication Protocol

➤ General Settings

Module makes use of serial communication. Communication configuration parameters are:

Baud rate	9600
Data bits	8 bits
Stop bit	1 bit
Parity bit	None

➤ Communication Command

There are two communication types: active upload type and Q&A type. The default type is active upload and it sends gas concentration once every second. Commands are as follow:

0	1	2	3	4	5	6	7	8
Start	Gas	Unit ppb	No decimal byte	Concentration (High byte)	Concentration (low byte)	Full range (high byte)	Full range (low byte)	Checksum
0xFF	0xC4	0x02	0x02	0XX	0XX	0x00	0x64	0XX

Gas concentration = concentration (high byte)*256 + concentration (low byte)

Switch to Q&A mode:

0	1	2	3	4	5	6	7	8
Start	Reserved	Switch command	Q&A	Reserved	Reserved	Reserved	Reserved	Checksum
0xFF	0x01	0x78	0x41	0x00	0x00	0x00	0x00	0x46

Switch to active upload mode:

0	1	2	3	4	5	6	7	8
Start	Reserved	Switch command	Active upload	Reserved	Reserved	Reserved	Reserved	Checksum
0xFF	0x01	0x78	0x40	0x00	0x00	0x00	0x00	0x47

To read gas concentration:

0	1	2	3	4	5	6	7	8
Start	Reserved	Command	Reserved	Reserved	Reserved	Reserved	Reserved	Checksum
0xFF	0x01	0x86	0x00	0x00	0x00	0x00	0x00	0x79

To return:

0	1	2	3	4	5	6	7	8
Start	Command	Concentration (High byte)	Concentration (low byte)	Reserved	Reserved	Concentration (High byte)	Concentration (low byte)	Checksum

		(ug/m3)	(ug/m3)			(ppb)	(ppb)	
0xFF	0x86	0xFF	0xFF	0x00	0x00	0xFF	0xFF	0xFF

Gas concentration = concentration (high byte)*256 + concentration (low byte)

Checksum calibration

/******

*Function name: unsigned char FucCheckSum(unsigned char *i, unsigned char ln)

*Function description: checksum calibration[Take Not(Byte1+Byte2+...Byte7) +1]

*Note: Take Not(Byte1+Byte2+...ByteX (X>2))

*****/

unsigned char FucCheckSum(unsigned char *i, unsigned char ln)

```
{
    unsigned char j, tempq=0;
    i+=1;
    for(j=0; j<(ln-2); j++)
    {
        tempq+=*i;
        i++;
    }
    tempq=(~tempq)+1;
    return(tempq);
}
```

Notes

- Avoid changing or moving sensor on the module.
- Avoid moving or changing electronic elements on PCB.
- Avoid exposure to organic vapour, organic solvent, high gas concentration.
- Protect from excessive vibration and shock.



普 | 晟 | PRO SENSE

ProSense Technologies Co., Ltd.

Add: Building4, Lianjian S&T Park, LonghuaDistrict, Shenzhen, China;

Tel: +86 755 3669 0079

Mobile: +8613510916915

Email: sales@szprosense.com

Website: www.szprosense.com