PS-VOC-100 Air Quality Module

Operation Manual

ProSense Technologies Co., Ltd.

Brief Introduction

PS-VOC-100 air quality module, works on the proven fuel cell technology, combines solid electrolyte with noble metal catalyst, converting VOC content into PPM directly. Once VOC arrives at working electrode (anode) it is oxidized instantaneously to generate an electrical signal. The electrical signal is then acquired and processed by microprocessor into a PPM value and is output by standard digital signal. PS-VOC-100 is pre-calibrated in the factory and can be integrated into your system directly.

Key Features

- High stability
- Good consistency
- Long service life
- No need for baseline correction
- Strong anti-poisoning ability
- No need for periodical calibration

Typical Applications

- Air cleaners/fresh air system
- Air conditioners
- Indoor air quality monitoring
- Portable devices
- Smart home

.....

Definition of Pins

PIN	DEFINITION
1	Vin(5V)
2	GND
3	RXD (0~3.3V data input)
4	TXD(0~3.3V data output)

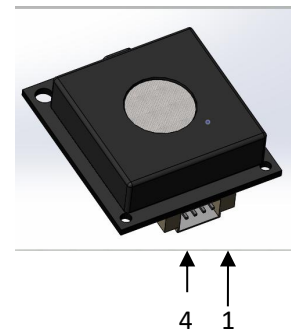

Diagram

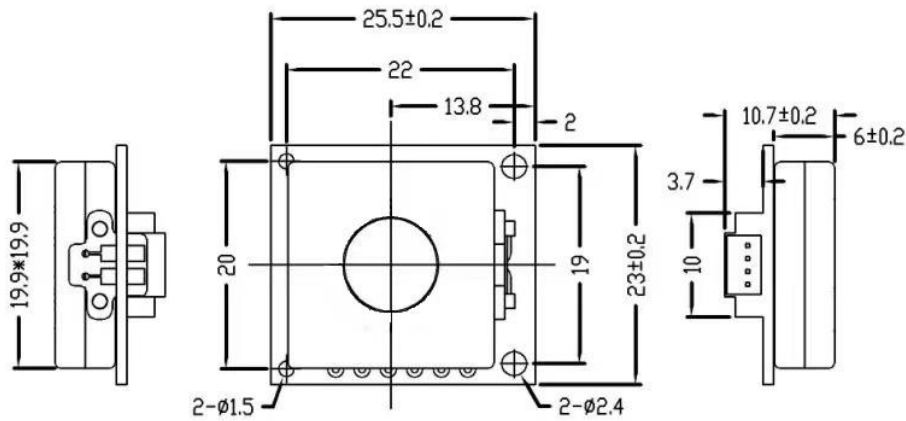

Technical Specification

MODEL	PS-VOC-100
Detection Principle	Micro fuel cell
Detectable Gas	Indoor air quality
Detection Range	0-100ppm
Overload	200ppm
Input Voltage	4.5-7V
Warm up time	<3min
Response Time (t90)	<90S
Recovery Time (t10)	<120S
Resolution	0.1ppm
Operating temperature range	-40℃~60℃
Operating Humidity Range	10%—90%RH (non-condense)
Calibration Gas	Alcohol
Lifetime	5 years
Warranty Period	12 months
Weight	4g

Communication Protocol

➤ General Settings

Module makes use of serial communication. Communication configuration parameters are:

Baud rate	9600
Data bits	8 bits
Stop bit	1 bit
Parity bit	None

➤ **Communication Command**

There are two communication types: active upload type and Q&A type. The default type is active upload and it sends gas concentration once every second. Commands are as follow:

0	1	2	3	4	5	6	7	8
Start	Gas	Unit ppb	No decimal byte	Concentration (High byte)	Concentration (low byte)	Full range (high byte)	Full range (low byte)	Checksum
0xFF	VOC=0x17	Ppb=0x04	0x00	0x00	0x25	0x07	0xD0	0x25

Gas concentration = concentration (high byte)*256 + concentration (low byte)

Switch to Q&A mode:

0	1	2	3	4	5	6	7	8
Start	Reserved	Switch command	Q&A	Reserved	Reserved	Reserved	Reserved	Checksum
0xFF	0x01	0x78	0x41	0x00	0x00	0x00	0x00	0x46

Switch to active upload mode:

0	1	2	3	4	5	6	7	8
Start	Reserved	Switch command	Active upload	Reserved	Reserved	Reserved	Reserved	Checksum
0xFF	0x01	0x78	0x40	0x00	0x00	0x00	0x00	0x47

To read gas concentration:

0	1	2	3	4	5	6	7	8
Start	Reserved	Command	Reserved	Reserved	Reserved	Reserved	Reserved	Checksum
0xFF	0x01	0x86	0x00	0x00	0x00	0x00	0x00	0x79

To return:

0	1	2	3	4	5	6	7	8
Start	Command	Concentration (High byte)	Concentration (low byte)	Reserved	Reserved	Concentration (High byte)	Concentration (low byte)	Checksum

		(ug/m3)	(ug/m3)			(ppb)	(ppb)	
0xFF	0x86	0x00	0x2A	0x00	0x00	0x00	0x20	0x30

Gas concentration = concentration (high byte)*256 + concentration (low byte)

Checksum calibration

/******

*Function name: unsigned char FucCheckSum(uchar *i,uchar ln)

*Function description: checksum calibration[Take Not(Byte1+Byte2+...Byte7) +1]

*Note: Take Not(Byte1+Byte2+...ByteX (X>2)

*****/

unsigned char FucCheckSum(unsigned char *i, unsigned char ln)

```
{
    unsigned char j, tempq=0;
    i+=1;
    for(j=0; j<(ln-2); j++)
    {
        tempq+=*i;
        i++;
    }
    tempq=(~tempq)+1;
    return(tempq);
}
```

Notes

- Avoid changing or moving sensor on the module.
- Avoid moving or changing electronic elements on PCB.
- Avoid exposure to organic vapour, organic solvent、high gas concentration.
- Protect from excessive vibration and shock.
-



普 | 晟 | ProSense Technologies Co., Ltd.
 PRO SENSE

Add: Building4, Lianjian S&T Park, LonghuaDistrict,Shenzhen,China;

Tel: +86 755 3669 0079

Mobile: +8613510916915

Email: sales@szprosense.com

Website: www.szprosense.com