

PS-H₂S-100 Hydrogen Sulphide Module

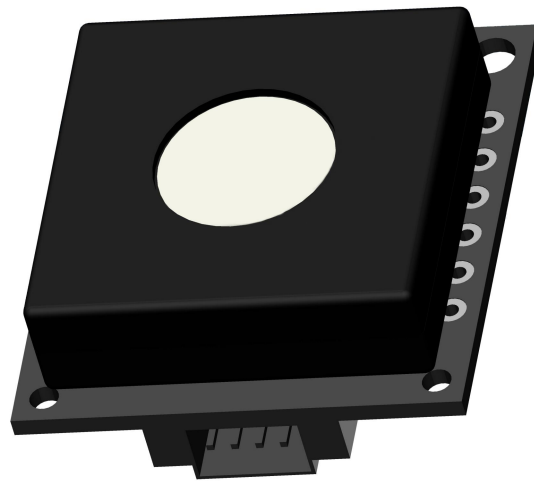

ProSense Technologies Co., Ltd.

Brief Introduction

PS-H₂S-100 hydrogen sulphide module combines selective H₂S sensor with high accuracy and advanced electronic control technology, converting H₂S concentration into PPM directly. PS-H₂S-100 selective H₂S module with high accuracy can be applied in smart toilets / smart home / aquatic farm and other cases where detection of H₂S at very low level is required. PS-H₂S-100 selective H₂S module is pre-calibrated in the factory and can be integrated into your system directly.

Typical Applications

Smart Toilets
 Portable devices
 Wearable devices
 Aquatic farm
 Green building
 Smart home

Key Features

High Accuracy
 High precision
 Fast response
 Long service life
 Selective detection
 High stability

Diagram

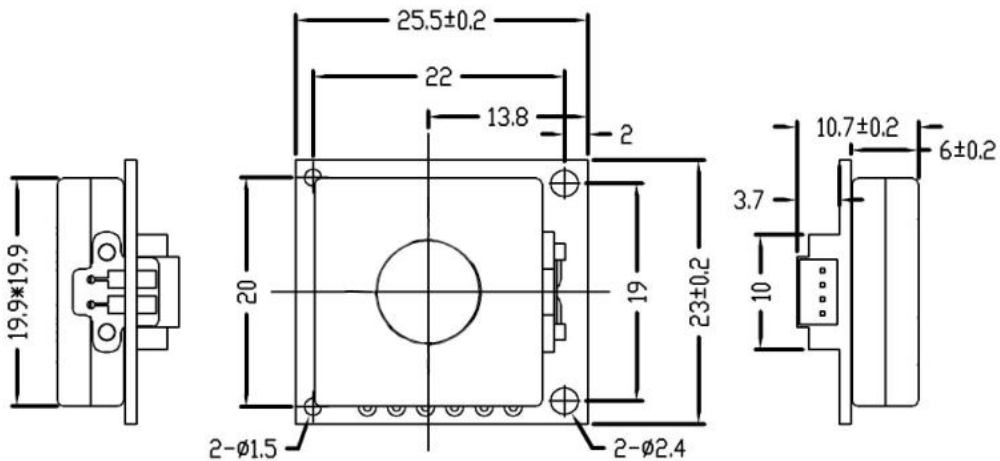

Definition of Pins

PIN	DEFINITION
Pin1	Vin(5V)
Pin2	GND
Pin3	RXD (0~3.3V data input)
Pin4	TXD(0~3.3V data output)

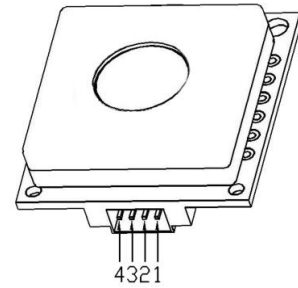

Technical Specification

MODEL	PS-H ₂ S-2
Detection Principle	Micro fuel cell
Detectable Gas	H ₂ S
Detection Range	0-100ppm
Overload	200ppm
Input Voltage	4.5-7V
Response Time (T90)	<15S
Resolution	1ppm
Operating temperature range	-40°C~70°C
Operating Humidity Range	10%—90%RH (non-condense)
Lifetime	5 years in air
Warranty Period	12 months
Weight	4g

Communication Protocol

➤ General Settings

Module makes use of serial communication.

Communication configuration parameters are:

Baud rate	9600
Data bits	8 bits
Stop bit	1 bit
Parity bit	None

➤ Communication Command

There are two communication types: active upload type and Q&A type. The default type is active upload and it sends gas concentration once every second. Commands are as follow:

0	1	2	3	4	5	6	7	8
Start	Gas	Unit ppb	No decimal byte	Concentration (High byte)	Concentration (low byte)	Full range (high byte)	Full range (low byte)	Check sum
0xFF	H2S=0x17	Ppb=0x04	0x00	0x00	0x25	0x07	0xD0	0x25

Gas concentration = concentration (high byte)*256 + concentration (low byte)

Switch to Q&A mode:

0	1	2	3	4	5	6	7	8
Start	Reserved	Switch command	Q&A	Reserved	Reserved	Reserved	Reserved	Checksum
0xFF	0x01	0x78	0x41	0x00	0x00	0x00	0x00	0x46

Switch to active upload mode:

0	1	2	3	4	5	6	7	8
Start	Reserved	Switch command	Active upload	Reserved	Reserved	Reserved	Reserved	Checksum
0xFF	0x01	0x78	0x40	0x00	0x00	0x00	0x00	0x47

To read gas concentration:

0	1	2	3	4	5	6	7	8
Start	Reserved	Command	Reserved	Reserved	Reserved	Reserved	Reserved	Checksum
0xFF	0x01	0x86	0x00	0x00	0x00	0x00	0x00	0x79

To return:

0	1	2	3	4	5	6	7	8
Start	Command	Concentration (High byte) (ug/m ³)	Concentration (low byte) (ug/m ³)	Reserved	Reserved	Concentration (High byte) (ppb)	Concentration (low byte) (ppb)	Checksum
0xFF	0x86	0x00	0x2A	0x00	0x00	0x00	0x20	0x30

Gas concentration = concentration (high byte)*256 + concentration (low byte)

Checksum calibration

/******

*Function name: unsigned char FucChecksum(uchar *i,uchar ln)

*Function description: checksum calibration[Take Not(Byte1+Byte2+...Byte7) +1]

*Note: Take Not(Byte1+Byte2+...ByteX (X>2)

*****/

unsigned char FucChecksum(unsigned char *i, unsigned char ln)

```
{
    unsigned char j, tempq=0;
    i+=1;
    for(j=0; j<(ln-2); j++)
    {
        tempq+=*i;
        i++;
    }
    tempq=(~tempq)+1;
    return(tempq);
}
```

Notes

- Avoid changing or moving sensor on the module.
- Avoid moving or changing electronic elements on PCB.
- Avoid exposure to organic vapour, organic solvent、 high gas concentration.
Protect from excessive vibration and shock.



ProSense Technologies Co., Ltd.

Add: Building4, Lianjian S&T Park, LonghuaDistrict,Shenzhen,China;

Tel: +86 755 3669 0079

Website:<http://www.szprosense.com>

Email: sales@szprosense.com