

Selective Formaldehyde Module

Model: DS-RF-24

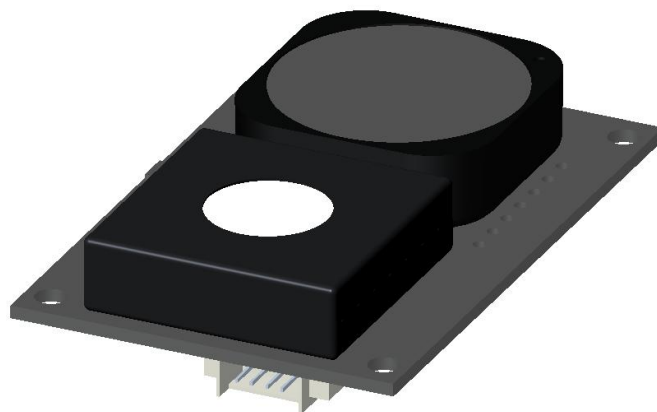

ProSense Technologies Co., Ltd.

Brief Introduction

DS-RF-24 selective formaldehyde module, the upgrade version of DS-RF, integrated the solid electrolyte with advanced production technique to realize the greatest improvement in performance/cost ratio. As DS-RF, this new version can detect HCHO, VOC, TVOC, t & RH at the same time, but with higher accuracy and stability.

Typical Applications

Smart home

Air purifier

Air conditioners

Portable devices

Wearable devices

HCHO detector

... ..

Key Features

Selective detection of HCHO

Detection of HCHO, VOC, TVOC, t, RH together

VOC & TVOC detection based on fuel cell tech.

High precision

Fast response

Long service life

High stability

Diagram

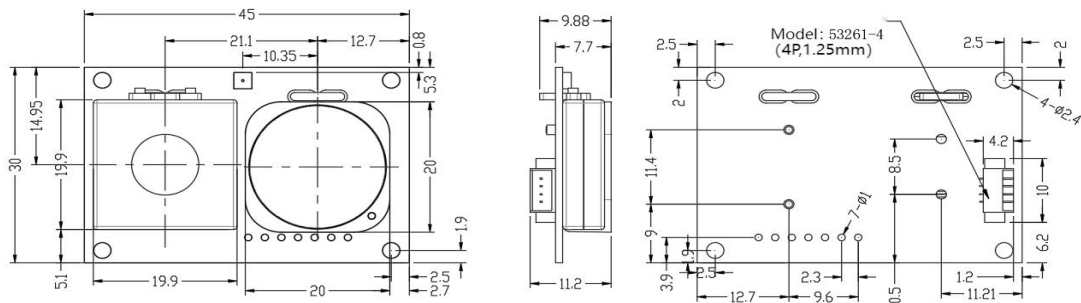

note: 1 All dimension is in mm

2 The tolerance is $\pm 0.15\text{mm}$

Definition of Pins

PIN	DEFINITION
Pin1	Vin(5V)
Pin2	GND
Pin3	RXD (0~3.3V data input)
Pin4	TXD(0~3.3V data output)

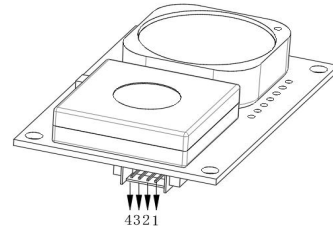

Technical Specification

MODEL	DS-RF-24		
Detection Principle	Micro fuel cell		
Detectable Gas	HCHO	VOC	TVOC
Detection Range	0-1ppm	0-10ppm	0-10ppm
Overload	2ppm	100ppm	100ppm
Resolution	0.001ppm	0.001ppm	0.001ppm
Accuracy	$\pm 25\text{ppb}$ or $\pm 10\%$ ($25\pm 3^\circ\text{C}$ & $50\pm 5\%\text{RH}$) whichever is greater	/	/
Input Voltage	4.5~7VDC		
Response Time (T90)	<120S		
Operating temperature range	$-40^\circ\text{C} \sim 70^\circ\text{C}$		
Operating Humidity Range	10%—90%RH (non-condense)		
Lifetime	6 years in air		
Warranty Period	24 months		
Weight	10g		

Cross Sensitivity of HCHO

Interference Gas	Concentration of Interference Gas(ppm)	Concentration of HCHO(ppm)
------------------	--	----------------------------

C ₂ H ₅ OH	2	<0.01
C ₆ H ₆	10	0
CH ₃ COOH	10	0
NH ₃	10	0
CO	1000	6
H ₂	1000	6

Communication Protocol

➤ General Settings

Module makes use of serial communication.

Communication configuration parameters are:

Baud rate	9600
Data bits	8 bits
Stop bit	1 bit
Parity bit	None

➤ Communication Command

There are two communication types: active upload type and Q&A type. The default type is active upload and it sends gas concentration once every second. Commands are as follow:

0	1	2	3	4	5	6	7	8	9	10	11	12	13
start	Reserved	C-high	C-low	C-high	C-low	C-high	C-low	±	t-high	t-low	RH-high	RH-low	Checksum
0XFF	0X05	HCHO ppb	HCHO ppb	VOC ppb	VOC ppb	TVOC ppb	TVOC ppb	t +:-0/-:1	t °C	t °C	RH %	RH %	XX

Gas concentration = C-high*256 + C-low

1ppm = 1000ppb

temperature = t-high + (t-low / 100)

humidity = RH-high + (RH-low/ 100)

Switch to Q&A mode:

0	1	2	3	4	5	6	7	8
Start	Reserved	Switch command	Q&A	Reserved	Reserved	Reserved	Reserved	Checksum
0XFF	0X01	0X78	0X41	0X00	0X00	0X00	0X00	0X46

Switch to active upload mode:

0	1	2	3	4	5	6	7	8
Start	Reserved	Switch command	Active upload	Reserved	Reserved	Reserved	Reserved	Checksum
0XFF	0X01	0X78	0X40	0X00	0X00	0X00	0X00	0X47

To read temperature and humidity:

0	1	2	3	4	5	6	7	8
Start	Reserved	Command	Reserved	Reserved	Reserved	Reserved	Reserved	Checksum
0XFF	0X01	0X3F	0X00	0X00	0X00	0X00	0X00	0XC0

To return:

0	1	2	3	4	5	6	7	8
Start	Command	±	t-high	t-low	RH-high	RH-low	Reserved	Checksum
0XFF	0X3F	+:0/-:1	t °C	t °C	RH %	RH %	0x00	XX

temperature = t-high + (t-low / 100)

humidity = RH-high + (RH-low/ 100)

To read gas concentration:

0	1	2	3	4	5	6	7	8
Start	Reserved	Command	Reserved	Reserved	Reserved	Reserved	Reserved	Checksum
0XFF	0X11	0X43	0X00	0X00	0X00	0X00	0X00	0XAC

To return:

0	1	2	3	4	5	6	7	8
Start	Command	C-high	C-low	C-high	C-low	Reserved	Reserved	Checksum
0XFF	0X43	HCHO ppb	HCHO ppb	VOC ppb	VOC ppb	0x00	0x00	XX

Gas concentration = C-high*256 + C-low

Checksum calibration

/******

*Function name: unsigned char FucCheckSum(uchar *i,ucharIn)

*Function description: checksum calibration[Take Not(Byte1+Byte2+...Byte7) +1]

*Note: Take Not(Byte1+Byte2+...ByteX (X>2)

*****/

unsigned char FucCheckSum(unsigned char *i, unsigned char In)

```
{
    unsigned char j, tempq=0;
    i+=1;
    for(j=0; j<(In-2); j++)
    {
        tempq+=*i;
        i++;
    }
    tempq=(~tempq)+1;
    return(tempq);
}
```

Notes

- Avoid changing or moving sensor on the module.
- Avoid moving or changing electronic elements on PCB.
- Avoid exposure to organic vapour, organic solvent、 high gas concentration.
- Protect from excessive vibration and shock.
- No recommended for industrial safety/personal monitoring, refer to 2-FP5.



ProSense Technologies Co., Ltd.

Add: Building4, Lianjian S&T Park, LonghuaDistrict,Shenzhen,China;

Tel: +86 755 3669 0079

Website:<http://www.szprosense.com>

Email: sales@szprosense.com

Mobile:+86-13510916915